



DESIGN AND INSTALLATION GUIDE
**PVC FITTINGS & LATERALS FOR
SOLID-WALL PVC SEWER PIPE**

PVC SEWER FITTINGS

TABLE OF CONTENTS

Introduction	2
Products	3
Main-Line Fittings & Service-Line Fittings	3 - 4
Connections to Dissimilar Materials	5
Options	5
Design	6
Burial Depth	6
Soil Compaction	7
Accommodating Pipe Movement	8
Other Considerations	9
Installation	10
Installation Recommendations	11
Member Company Fitting Manufacturers	12

PVC SEWER FITTINGS

INTRODUCTION

This document has been developed by the Uni-Bell PVC Pipe Association for design and installation of PVC fittings where solid-wall PVC pipe is used in non-pressure applications.

The guide provides information on the wide range of fittings that are available for various dimension ratios and outside diameters of PVC pipe through 60-inch.

Also included is information on installation practices that are intended to optimize the performance of PVC fittings.

Standards

Product standards used in this guide include:

- ASTM D3034 “Standard Specification for Type PSM Polyvinyl Chloride (PVC) Sewer Pipe and Fittings”
- ASTM D3212 “Standard Specification for Joints for Drain and Sewer Plastic Pipes Using Flexible Elastomeric Seals”
- ASTM F679 “Standard Specification for Polyvinyl Chloride (PVC) Large-Diameter Plastic Gravity Sewer Pipe and Fittings”
- ASTM F1336 “Standard Specification for Polyvinyl Chloride (PVC) Gasketed Sewer Fittings”
- CSA B182.2 “PSM Type Polyvinyl Chloride (PVC) Sewer Pipe and Fittings”

Installation standards used in this guide include:

- ASTM D2321 “Standard Practice for Underground Installation of Thermoplastic Pipe for Sewers and Other Gravity-Flow Applications”
- CSA B182.11 “Standard Practice for the Installation of Thermoplastic Drain, Storm, and Sewer Pipe and Fittings”

Specifications

- PVC sewer pipe shall conform to ASTM D3034 (3-inch through 15-inch), ASTM F679 (18-inch through 60-inch), or CSA B182.2 (4-inch through 60-inch).
- PVC fittings shall conform to ASTM 3034, ASTM F1336, or CSA B182.2.
- PVC bell-and-spigot push-on type joints shall be gasketed, conforming to ASTM D3212.
- All PVC sewer pipe and fittings shall be installed in accordance with ASTM D2321 or CSA B182.11.

PVC SEWER FITTINGS

PRODUCTS: MAIN-LINE & SERVICE-LINE FITTINGS

Fittings commonly used in the sewer main line are bends, couplings, adaptors, tees, wyes, and tee-wyes.



A wide assortment of fittings are available



Bends

Bends: The most common fittings found in service lines are bends, which are used to accommodate changes in direction. Bends of various angles are available. Bends can be fabricated to meet a wide variety of design requirements.

Couplings: A full range of PVC couplings are available to connect pipe.

Repair couplings: PVC gasketed repair couplings are available where cut-in of a service fitting is required.

Reducer couplings: Adaptors that connect different diameters of pipe.



Reducer couplings



Transition coupling

Transition couplings: Adaptors to connect different OD-types of PVC pipe are available in both spigot-end and gasketed bell. In the example shown, an 8-inch PVC PSM spigot (8.400-inch OD) is connected to an 8-inch PVC IPS OD spigot (8.625-inch OD).

PVC SEWER FITTINGS

PRODUCTS: MAIN-LINE & SERVICE-LINE FITTINGS (CONT.)

Fittings with service-line branches: Main-line fittings with service-line branches are available in tee, wye, or tee-wye configurations.



Service-line branches

Tapping saddles: PVC tapping saddles are available in tee and wye configurations. Saddles may be used when a service line is added to an existing system. After a hole is cut in the main line, the PVC saddle is attached with stainless steel bands. Saddles are not recommended where an air test is required.



Saddles

PVC SEWER FITTINGS

PRODUCTS: CONNECTING TO DISSIMILAR MATERIALS

A new PVC line, main line or a service line, will sometimes be connected to an existing line of a different material. In these cases it is not uncommon to see a flexible coupling used to make the connection. The existing line will probably not experience any additional settlement, but the new line laid on disturbed soil may undergo settlement. PVC sleeves or stainless steel bands on the flexible coupling will aid in preventing an offset between the two pipes.



Sleeve



Stainless steel band

PRODUCTS: OPTIONS

Both injection-molding and fabrication processes are used to produce non-pressure PVC fittings. Fabrication gives the ability to manufacture an unlimited variety of fittings to meet design requirements such as:

- Special dimensional requirements (e.g., lay length)
- Heavy-walled branches
- Fittings with connections that accommodate different PVC pipe diameter types



Custom fabrication

PVC SEWER FITTINGS

DESIGN: BURIAL DEPTH

The critical design consideration for fittings is *stress*, not depth of bury. Excessive stress can be created at any depth, including shallow-bury installations.

Definitions

- Lateral: pipe running from sewer main to property-line connection
- Riser (or stack): a steep-sloped lateral

A riser pipe can place extreme loads on fittings if a drag-down or push-down scenario occurs. Using the correct fittings and installation practices allows for minimal loads to be placed on fittings at depths in excess of 30 feet.

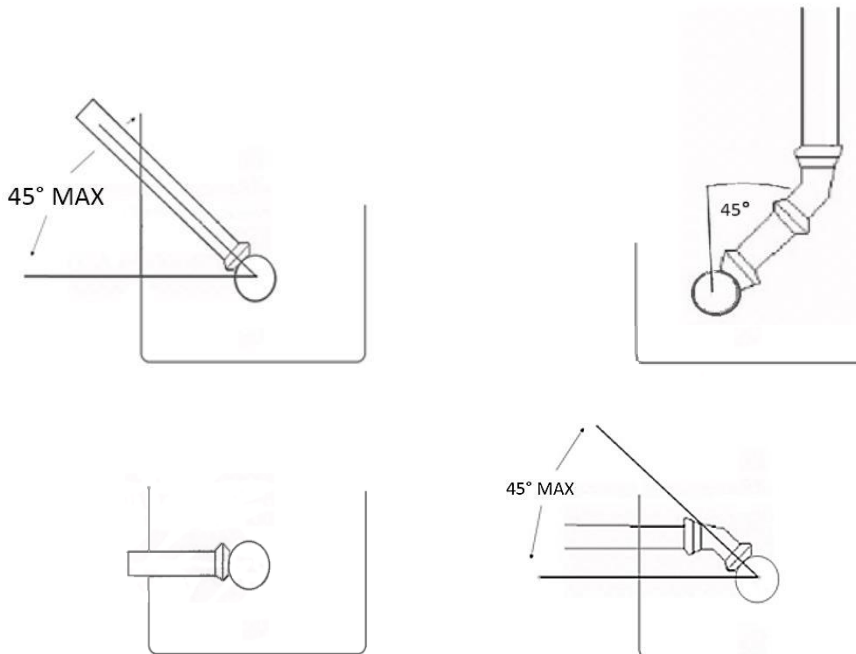
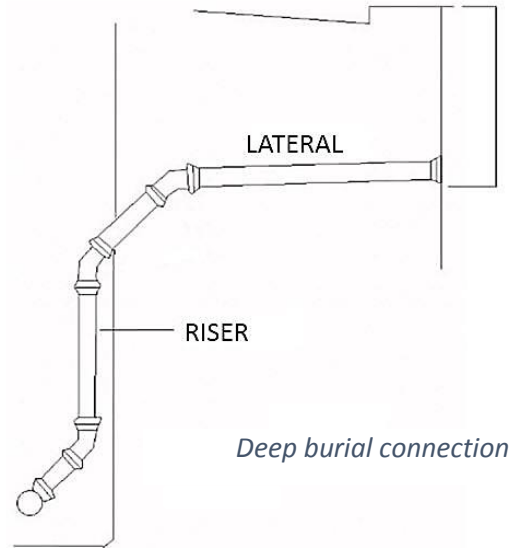

Typical connections

PVC SEWER FITTINGS

DESIGN: SOIL COMPACTION

Adequate soil compaction around riser pipe is required so that the pipe does not move downward. Pipe laid in either vertical or horizontal orientation can create stresses on fittings when the pipe is allowed to move.

Any settlement of material alongside the riser produces a “drag-down” load due to the frictional forces at the pipe-soil interface. Settlement of the lateral fitting assembly produces a similar drag-down load. These loads must be mitigated or transferred harmlessly off the stack to prevent problems such as joint over-insertion, spearing, punch through, fitting fracture, and deflection or misalignment of the sewer main.

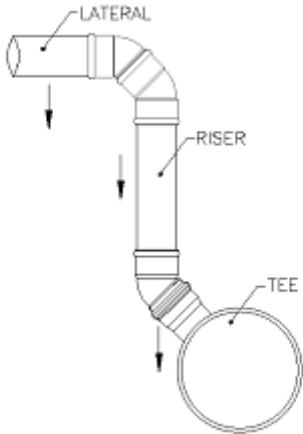

Forces on risers and lateral

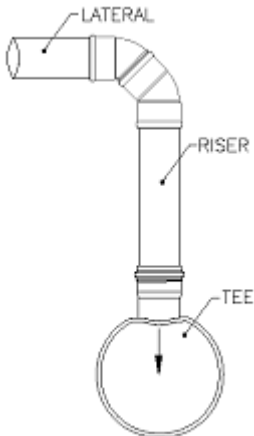

Deflection of main-line

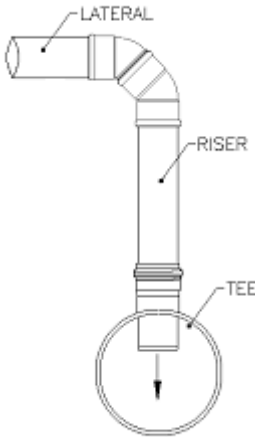

Punch through or spearing

PVC SEWER FITTINGS

DESIGN: ACCOMMODATING PIPE MOVEMENT

There are two strategies used to accommodate differential settlement:

1. Resist movement – use a stronger fitting to resist stresses – this has the disadvantage of moving the loads elsewhere rather than solving the problem
2. Allow movement – prevent stresses from occurring

Spigot-by-spigot adaptor: For steeper portions of risers, nipples are used to provide bell-to-bell contact. This contact prevents over-insertion of the spigot into the bell.

Deep-socket fittings (controlled-settlement joints): These fittings accommodate downward movement of a vertical riser pipe. The objective is to prevent the riser pipe from making contact with the socket bottom. Extra travel is also provided by standard-depth fittings if the insertion depth recommendations of the fittings manufacturer are followed.

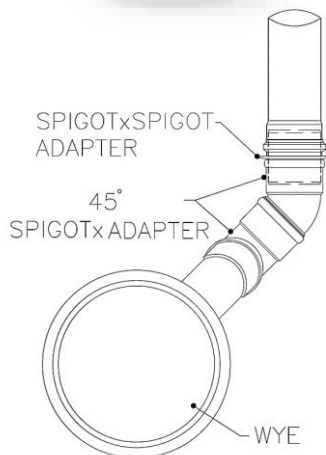

Spigot by spigot adaptors

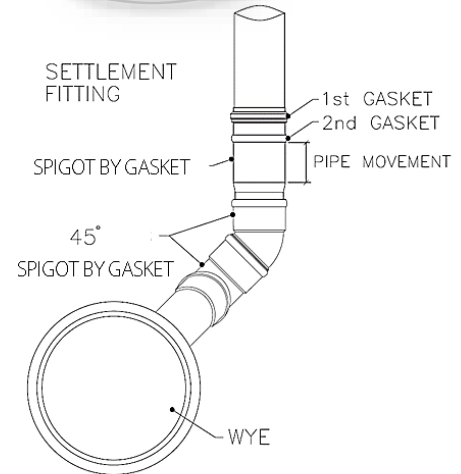

Deep-socket fitting

PVC SEWER FITTINGS

DESIGN: OTHER CONSIDERATIONS

- Pipes with lower DRs are thicker-walled and provide increased pipe-stiffness values.
- When it is necessary to install a vertical riser, engineering design is required to accommodate the anticipated movement of the riser pipe.
- It is recommended that a tee, wye, or tee-wye fitting not be installed vertically without engineering design, since it is difficult to provide proper support for the fitting branch.
- Compaction is critical beneath the main-line sewer, fittings, and any horizontal portion of lateral to minimize or eliminate settlement and the resulting loading.
- In general, service laterals should be at an angle of no greater than 45 degrees from the horizontal. This will minimize downward loads on the service connection caused by side-soil friction.
- Other options such as heavy-walled fittings, solvent-cement fittings, concrete encasement, and flowable fill can be used if site conditions make it impractical to achieve adequate compaction of the backfill materials.

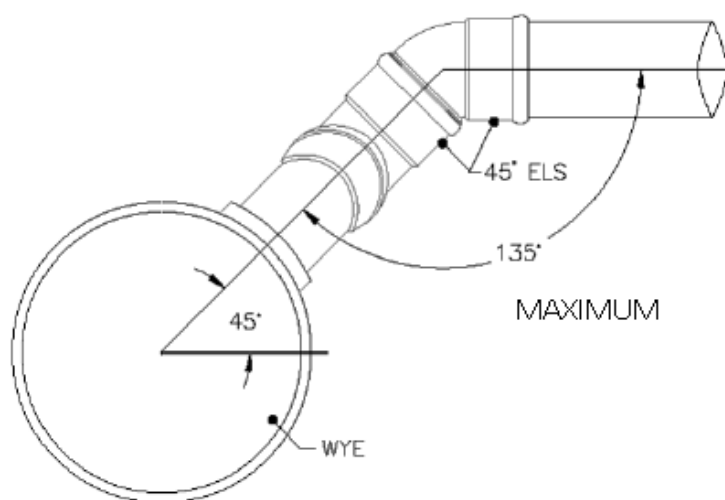

Lateral connection

PVC SEWER FITTINGS

INSTALLATION

- All connections between pipe and fittings should be made in straight alignment.
 - Bending of the riser pipe for grade or angle adjustment should not take place.
 - Service laterals and fittings should be installed without angular joint deflections.
- Local specifications may require the PVC service line to be a different OD type from the main line. It is not unusual to have PVC service lines with IPS (Iron Pipe Size) dimensions coming off a PVC main that has PSM (Plastic Sewer Main) dimensions.
- Transitions from horizontal to vertical should be smooth and well-supported. This may be accomplished with fitting combinations, gradual bends and/or trench geometry.

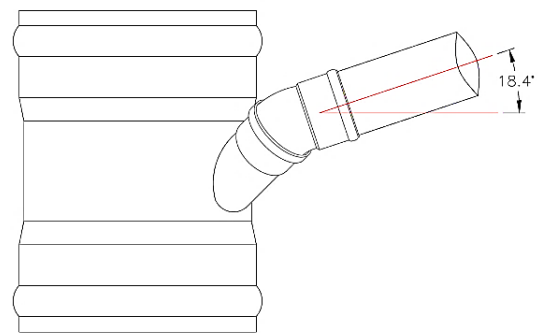
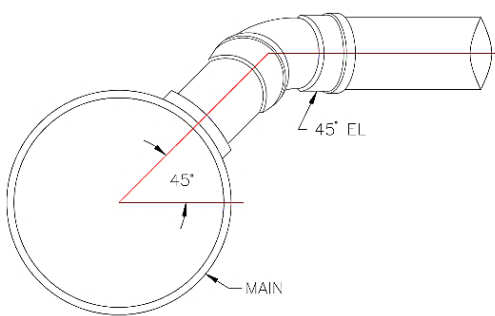

45 degree bend results in 18 degree offset

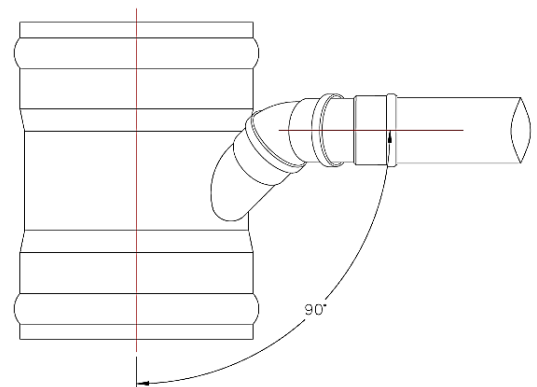
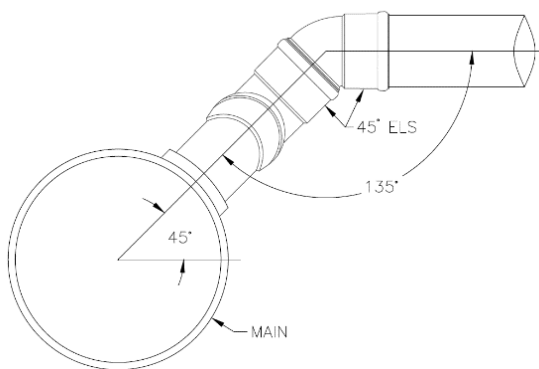

45 degree bends in straight alignment

PVC SEWER FITTINGS

INSTALLATION RECOMMENDATIONS

- Understand the soil conditions and installation practices. Heavy-walled PVC fittings may be required when working in unstable soil conditions.
- When rotating a main-line fitting, use the bell on the body for leverage. Do not place a pipe or bar into the service line for this purpose as this could cause damage to the fitting.
- Use a single length of pipe for the riser section whenever possible.
- Field cut pipe clean and square. A beveled square cut engages the entire circumference of the bell, while an uneven cut results in stress concentrations due to point loading.
- Follow the fitting manufacturer's recommended insertion depth. The pipe manufacturer's insertion mark may differ from that for a fitting.
- Where native material is stable, lay the service on undisturbed native soil.
- Where possible, install vertical risers along the trench wall with adequate support provided at the transition to horizontal.
- Compact embedment material in lifts to provide a proper transition between the undisturbed native material and the riser.
- Hand place a minimum 6-inch layer of initial material over the top of a riser laid on undisturbed soil to provide protection to the risers during final backfill. Where risers are laid on disturbed soil, additional thickness of protective material may be required.
- Prevent heavy equipment from driving over riser systems and cleanouts as this could push the soils and riser system downward.

PVC SEWER FITTINGS

FOR FURTHER INFORMATION, CONTACT A UNI-BELL MEMBER
COMPANY FITTING MANUFACTURER:



Galaxy Plastics

<http://www.galaxyplastics.com/>



<http://www.ipexna.com/>



<http://www.gpk-fargo.com/>



<http://www.royalbuildingproducts.com/>



<http://www.harcofittings.com/>



<http://www.specifiedfittings.com/>



<http://www.tigre.com/usa/web/index.p>



UNI-BELL PVC PIPE ASSOCIATION
2711 LBJ Freeway, Suite 1000
Dallas, TX 75234
(972) 243-3902

WWW.UNI-BELL.ORG

(09.01.15)

UNI-PUB 12-15